



Letters to the editor

.....

Dear Editor

Before I enter the discussion on Mr Popa's recent article in L| A Vol. 1 and the letter of Mr Wood I want to point out that all equations and determination processes I will present in this discussion are based on two sources only: data-sheet information and 'Electronic Circuits' Handbook for Design and Applications, Tietze/Schenk, Springer Ed. 2008, ISBN978-3-540-00429-5. It's the main source of my books too and it's a kind of standard used in German universities of technology.

When dealing with electronic noise issues I do not use simulation software nor do I trust them. In addition, I guess that most readers have no access to one of these rather expensive software packages. I'm only extravagant with the math software Mathcad MCD 11 & 13; however, the whole presented calculation course should be made available in MCD 2000 by yourself, the editor; it's a rather cheap MCD version on the markets of used software. *(I was able to buy a Student Version of MathCad 13 some years ago; I am not familiar with the 2000 version though - ed.)*

Mr Popa's is article very interesting, and I strongly recommend studying the info given on Mr Popa's web-site [2] as well. There, at the end of the measurement section, he shows two HPS 5.1 graphs (L & R?), each of them including the trace of the input referred non-equalized equivalent noise voltage density with input shorted. In addition he marked the 1,059Hz noise voltage density values: 314.187pV/rtHz {1} and 326.157pV/rtHz {2} respectively. I guess, after 362 averages these figures can be taken as anchor points.

In addition I've studied Mr Wood's remarks on the Popa article http://www.linearaudio.net/userfiles/file/letters/Volume_1_LTE_OP.pdf . In both versions there are points I disagree with (mainly the simplifications of equations) and others I fully agree with. My remarks are split into two parts as follows:

1. Constant Current Source (CCS) Discussion

A very good example on the simplification of equations is the discussion on the CCS. Mr Popa's simplification approach leads to his Eq. (5), which does not hit reality when talking about collector currents in the range of his HPS 5.1 head-amp / phono-amp. In any case, to calculate the output noise current density of a BJT-CCS the following equation should be used (the 2nd term alone is not enough here):

$$i_{n,ol} = \sqrt{i_{n,T1}^2 + \frac{4kTB_1}{R_L}} \tag{0.1}$$

It is based on the Fig. 1 circuit (left) and its equivalent circuit (right). It should/could replace the 100R resistance R201 of the head-amp. The attached Mathcad worksheet's point 5 gives all other equations that



are needed to use Eq. (1.1). As a result (marked (7) on the WS), the current noise density $i_{n,o1}$ of the CCS becomes 1.21 times the current noise density $i_{n,RL}$ of the 100R resistance at $I_C = 96mA$. In case someone needs them I've added the voltage noise relevant calculations too. The MCD worksheet allows playing around with all parameters, eg. a change from 96mA to 200µA changes factor 1.21 to factor 1. The voltage noise goes the other way round: the factor 1.055 changes to 1.321. I've assumed a T1 with 1/f-noise corner frequencies f_{ci} and f_{ce} each < 20Hz. Otherwise, we should take it into account.

The inclusion of such a CCS would increase the gain of the head-amp's 1st stage to ≥ 100 , assuming we find the right Early voltage of T1. I've taken the worst-case value: -30V. The determination of V_E by use of the data-sheet is described in Fig. 2.5 of the above mentioned book. To avoid trouble with interfering 'A's on a MCD worksheet (we have A-mpère, A-weighting function A(f), etc.) I use V_E here instead of the widely used V_A .

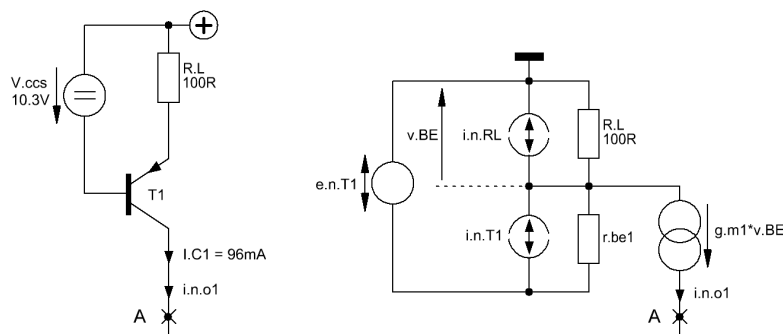

Fig. 1 Typical and simple BJT CCS (left) and its equivalent circuit (right)

The main disadvantage of R_L 's replacement by a CCS will be the reduction of the gain-stage's overload margin or the increase of the power supply to keep the original overload margin, however, this might be surpassed by the advantage of stronger closed-loop feedback because of the higher gain in an open-loop, thus reducing distortion and output resistance by the same amount.

2. Head-Amp / Phono-Amp Noise Discussion

In his article Mr Popa claims that the measured equivalent input noise voltage density value of 0.32nV/rtHz {3} is close to the calculated one of 0.33nV/rtHz {4}. Indeed! However, this claim would be true only as long as the values of {3} and/or {4} would be correct and comprehensible. Unfortunately, the text does not allow verification and I strongly doubt that {3} and {4} are correct, not only because of the missing indication of the frequency range or frequency of validity.

In this respect the first question becomes: how did Mr Popa get the measured value of 0.32nV/rtHz. Is it simply the middle between the two graph values at 1,059Hz, already mentioned in the 3rd paragraph? And - the 2nd question - how did he get the calculation result of 0.33nV/rtHz? None of the equations of his article led us to that result. The closest value comes from his specially derived approximation equation Eq. (11): 0.309nV/rtHz, assuming that the gain-stage's $g_m = 260mS$ for 8 JFETs. This result does not tell anything about its frequency dependency, hence it is not useful to completely describe the input referred noise voltage density in the audio-band (20Hz ... 20kHz = B_{20k}) of the head-amp nor will it allow a precise calculation of the signal-to-noise ratios (SNs).

Despite his unusual treatment of units (eg. Eq. (3): left side unit = S, right side unit = A) I only pick out the point of his calculations and equations that feeds my doubts most. Mr Wood has already tackled the issue



concerning the JFET noise current in Table 1. In contrast to Mr Popa's statement in Table 1 and by ignoring any 1/f-noise effect the equation to calculate the equivalent rms input noise current density $i_{n,i}$ in a bandwidth of $B_1 = 1\text{Hz}$ becomes:

$$i_{n,i}^2 = \frac{8}{3} k T g_m B_1 \tag{0.2}$$

Maybe it's simply a number turn of 2 vs. 3. In general, the wrong noise current leads to wrong voltage noise calculation results (see Table 1, column E, line 6 vs. lines 7, 8). Nevertheless, the full-blown frequency and input load resistance R_0 dependent equation to calculate the open-loop output noise voltage density $e_{n,o,0}(f)$ of Mr Popa's head-amp looks like (the R_0 dependency allows easy calculation of SNs, for comparison reasons we set here $R_0 = 0\Omega$):

$$e_{n,o,0}(f, R_0) = \sqrt{\left[e_{n,i,8JFET}^2(f) + e_{n,RS,eff}^2(f) + e_{n,R0,eff}^2(R_0) + \left(\frac{e_{n,i,op211}}{G_{1st}} \right)^2 \right] (g_{m,8,red} R_{F1})^2 + (i_{n,RL,eff}^2(f) + i_{n,i,op211}^2) R_{F1}^2 + e_{n,RF1}^2} \tag{0.3}$$

Thus, the input referred noise voltage density of the amp becomes:

$$e_{n,i,amp}(f, R_0) = \frac{e_{n,o,0}(f, R_0)}{g_{m,8,red} R_{F1}} \tag{0.4}$$

$$g_{m,8,red} = \frac{8 g_{m1}}{1 + R_S 8 g_{m1}}$$

The corresponding circuit with all the above mentioned noise-making terms is shown in Fig. 2. From a noise generation point of view T1 represents the cascode of the input JFET and the output BJT. The BJT has no influence on the noise production of the cascode amp.

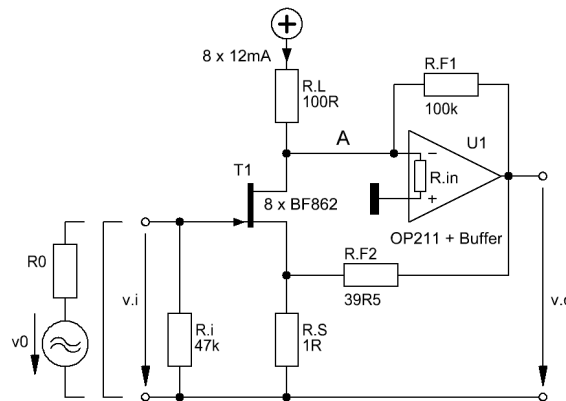

Fig. 2 Principal HPS 5.1 circuitry with all noise relevant components



With the Eq. (1.3) calculation approach we will avoid noise current problems at point A. Nevertheless, the respective equation is given on the MCD WS too. In addition, and this is the main reason why I've chosen the Eq. (1.3) approach, we can use the 1/f-noise corner frequency of Mr. Popa's noise voltage density curves to derive the 1/f-noise corner frequency f_c of the 8 JFETs without big additional transfers into a more noise current mode oriented Eq. (1.3).

The two Eqs. (1.3) and (1.4) include all relevant noise sources without any simplification of their respective formulae, e.g. the 1/f-noise of the JFETs, the frequency dependent excess-noise of the source resistor R_S and of the drain load resistor R_L , the drain-source resistance of the JFETs r_{DS} , etcetera. The Early voltage V_E is graphically derived from the data-sheet. It yields an r_{DS} of 833.333Ω , a value not far away from the one given by Mr Wood (713Ω). As R_{F1} I assume that $100k\Omega$ would be sufficient. Here, no resistance would increase the danger of oscillation and unclear phase and frequency dependency. The MCD WS allows playing around with all parameters and it clearly shows the influence of all parameters on the input referred noise voltage density, before we could simplify or round any result.

The approach on how to get the 1/f-noise corner frequency f_c of the JFETs looks as follows:

In B_{20k} Mr Popa's zoomed web-site graphs allow determining the amp's 1/f-noise corner frequency by picking out $f_{c,amp} \approx 600Hz$. Outside B_{20k} the traces show the typical behaviour of increasing noise levels $>100kHz$ (theory: $+6dB/oct.$) and more than $+3dB/oct <20Hz$ increasing noise components, mainly injected by additional unpredictable low-frequency artefacts. Within the B_{20k} sector we have a rather perfect 1/f-noise part followed by a white-noise section up to $20kHz$. With that we can graphically derive the f_c of the JFET's: $f_c \approx 1,100Hz$. It would be possible precisely calculating f_c . However, this calculation would also depend on the guessing of $f_{c,amp}$. $1,100Hz$ falls in the range of typical f_c values for many modern low-noise JFETs.

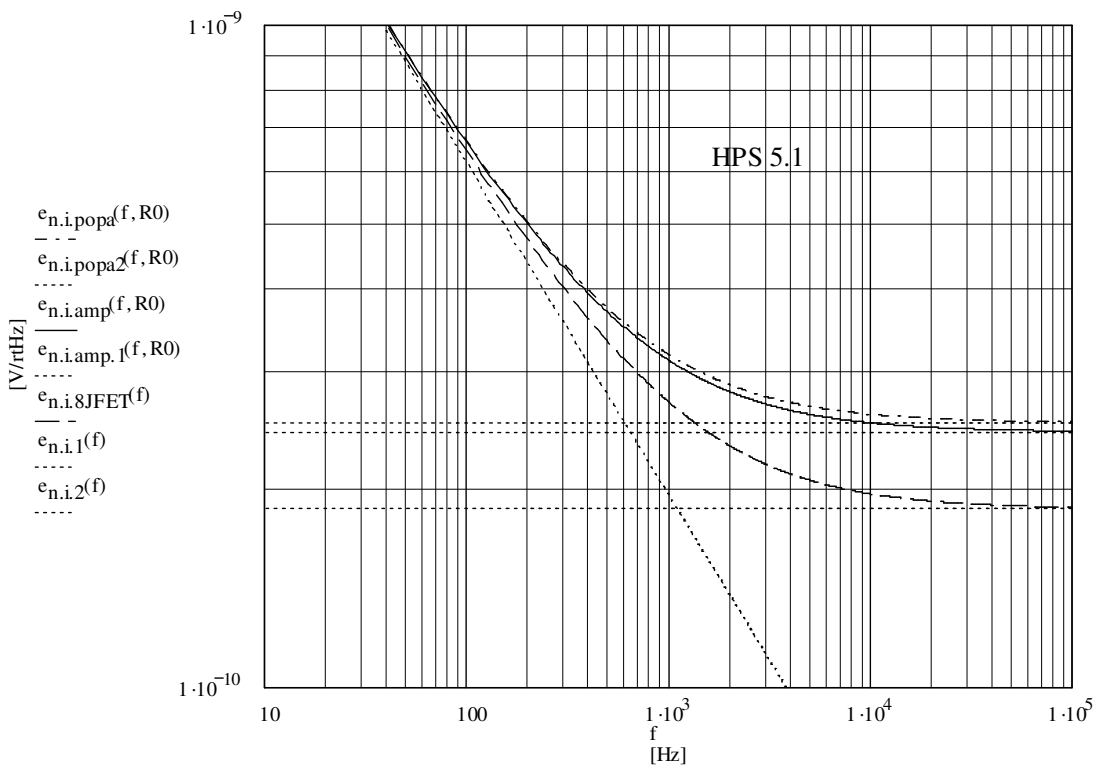

Fig. 3 Determination of the 1/f-noise corner frequency of the HPS 5.1; the traces are created with variants of Eqs. (1.3) and (1.4) (see MCD WS)



I assume equal f_c for all 8 JFETs. The different noise voltage density situations of the input stage are summed-up in Fig. 3. The dotted horizontal lines are the tangents of the equivalent noise voltage density traces of the 8 JFETs (dashed bottom curve) and the math simulation (dashed-dotted top curve) of Mr Popa's upper web-site curve. The 1/f-noise tangent of all traces is dotted too and decreases with 3dB/oct.. As a trial the changing of f_c moves all traces horizontally. The movement should be stopped at the point where the dotted horizontal tangent of the Popa-amp trace (top dashed-dotted trace) cuts the dotted 1/f-noise tangent at 600Hz. Automatically the dotted horizontal tangent of the dashed JFET trace crosses the 1/f-noise tangent at appr. 1,100Hz. The solid middle curve represents my calculated input referred noise voltage density $e_{n,i,amp}(f,R_0)$. Of course, the top trace and the middle trace include the bottom trace's impact.

The tiny difference between the middle solid trace and the dashed-dotted top curve mirrors the exactness of the chosen calculation approach. This difference could be expressed in terms of a resistance R_x . With $R_x = 0\Omega$ my calculation would exactly hit the simulated trace of Mr Popa's web-site upper curve. The value of R_x is mainly dependent on the voltage value of a known point on the measured Popa-trace. Fortunately, Mr Popa has fixed one, {1} at 1,059Hz. So, as long as the simulated dashed-dotted trace (= solid trace plus R_x at 1,059Hz) includes at least $f_{c,amp}$ and {1} and the 1/f-noise decreases with 3dB/oct. (not exactly, because of the excess-noise influence of R_S and R_L , but it's very very close) and the white-noise region is based on all the noise elements that are included in Eqs. (1.3) and (1.4) at a frequency far outside the audio-band (eg. 10^9 Hz) we can be sure that we will hit reality as close as possible.

The consequences of the above given remarks should be: in the described low-resistance environment Mr Popa's equation simplification processes seem to go too far. It is better going through the complete calculation process first and doing the simplification or rounding later. In addition it makes no sense bringing result numbers on the table that cannot be derived from the presented equations and/or formulae. That's why partly correspondences of result numbers look a bit like 'by accident'.

1/A	B	C	D		E	F	G	H		I	J
2	owner	source	i/p noise voltage density at $R_0 = 0\Omega$		character	frequ. range	remarks		action	method	Eq. on MCD WS
3			pV/rtHz								
4	O. Popa	LA vol. 1	$e_{n,i,m}$	320.0	?	?	meas.	?			n. a.
5	"	LA vol. 1	$e_{n,i,calc}$	330.0	?	?	calc.	?			
6	"	LA vol. 1	$e_{n,i,p,gs}$	309.2	frequency-independent	infinite	calc.	Eq. (11)			(1)
7	BuVo	Via $SN_{i,amp}$ calculation	$e_{n,i,avg1}$	268.4	average in:	B_{20k}	calc.	complete calculations on separate Mathcad worksheet			(2)
8	"	Via simulated $SN_{i,popa}$	$e_{n,i,avg2}$	275.5	average in:	B_{20k}	calc.				(3)
9	"	rough calculation + 1/f	$e_{n,i,avg3}$	253.4	average in:	B_{20k}	calc.				(4)
10	"	data-sheet values + 1/f	$e_{n,i,avg4}$	356.4	average in:	B_{20k}	calc.				(5)
11	"	via BF862 + R_S + no 1/f	$e_{n,i,avg5}$	310.8	frequency-independent	infinite	calc.				(6)
12	B. Wood	letter to O. Popa	$e_{n,i,wood}$	461.0	?	?	calc.				no

Table 1 Overview of various calculation results.
The J column's (x) refers to corresponding marks of the results on the MCD worksheet

I've summed-up the main findings in two tables. Table 1 gives an overview on the results of various approaches to calculate amp input noise voltages. Of course, the result in line 8, column E looks like the



most correct one. However, we need to know at least one value of the measured noise spectrum. If that could not be reached the result of box 7/E comes closest to the measured result. Because of their non-white-noise character the results in the boxes E / 7 - 10 can only be average figures in B_{20k} , whereas the results of boxes E / 6 and 11 show frequency independent figures. It seems as if the Popa and Wood figures of boxes E / 4, 5, and 12 are frequency independent too.

Table 2 dives a bit deeper in the comparison issues. It shows several SNs that could be calculated with the values of the boxes E / 7, 8, and 9 from Table 1, based on different input loads R_0 and 1/f-noise dependencies. The filling of the boxes marked with '?' would help to better understand things as well as it would allow comparisons between calculated and measured results.

Anyway, we all know that the right math is only one side of the coin; the other side is craftsmanship brought to bear on the piece of electronic on our work bench in front of us. Therefore, in the end, let's have a look on the corresponding non-equalized input referred signal-to-noise ratios SN_i in B_{20k} too. Of course, the calculations are also part of the above mentioned Mathcad worksheet. Here, Mr Popa's HPS 5.1 looks really great and he's got the right intuition on a top solid-state solution for MC and MM purposes.

1/A	B	C	D	E	F	G	H
2	input referred SNs ↓	unit ↓	BuVo detailed calculation incl 1/f	BuVo rough calculation excl 1/f	BuVo's Popa simulation incl 1/f	Popa measurement	R0 [Ω]
3	Mathcad WS reference →		4.1 $e_{n.i.amp}$	4.2 $e_{n.i.tot}$	4.1 $e_{n.i.popa}$		
4	$SN_{i,amp}$	dB	-82.4	-83.6	-82.2		
5	$SN_{ne,R0}$	dB	-74.9	-75.1	-74.9	?	20.0
6	$SN_{ne.a,R0}$	dB(A)	-77.0	-77.2	-76.9	?	20.0
7	$SN_{riaa,R0}$	dB	-75.5	-78.8	-75.4	?	20.0
8	$SN_{ariaa,R0}$	dB(A)	-82.6	-83.0	-82.6	?	20.0

Table 2 SN calculation results for $R_0 = 0\Omega$ and 20Ω

In the equivalent noise bandwidth B_{20k} and with an input reference level of $0.5mV_{rms}$ the SN_i of the Eq. (1.4) based input noise voltage becomes - 82.399dB. The simulated result becomes slightly worse: -82.171dB. Both figures indicate fantastic low SN values for MC phono-amps or head-amps with shorted inputs. I guess they will beat the solid-state record holders on the market. The following quick check will tell us why.

Comparisons with other market offers require calculations (again with Eq. (1.4)) of all input referred SNs based on a specific input load, usually made up by $R_0 = 20\Omega$, and with A-weighting in B_{20k} (Note: the MCD WS allows a change to other R_0 figures and other measurement bandwidths; this will yield other SN results!). Hence, we get for the non-equalized head-amp: $SN_{ne,20R} = - 74.916dB$, with A-weighting: $SN_{ne.a,20R} = - 76.985dB(A)$, and for the RIAA equalized phono-amp: $SN_{riaa,20R} = - 75.484dB$ (we're losing here appr. 3.3dB because of the 1/f-noise impact and the heavy RIAA transfer induced gain at the low-end of B_{20k}), and with A-weighting $SN_{ariaa,20R} = - 82.643dB(A)$. Table 2 gives the rounded figures.



As far as I know the actual commercial record holder is the Accuphase C-27 with an AP-measured $SN_{\text{ariaa.20R}} = -81.5\text{dB(A)}$ in B_{20k} (stereoplay 12-2009). I guess, without any hum impact the filled-in numbers of the '?' boxes in Table 2 will lead to results within $\pm 0.5\text{dB}$ from the calculated values of column D, however, as long as they are strictly based on an equivalent noise bandwidth B_{20k} .

Burkhard Vogel
Stuttgart, Germany

Attachment: The detailed MathCad noise analysis is reprinted below and the MathCad file itself can be found at http://www.linearaudio.net/letters/bv_to_op_v1_02.mcd.



Noise evaluation of Mr Popa's HSP 5.1 head-amp/phono-amp

$k := 1.38065 \cdot 10^{-23} \text{V}\cdot\text{A}\cdot\text{s}\cdot\text{K}^{-1}$ $q := 1.6022 \cdot 10^{-19} \text{A}\cdot\text{s}$ $T := 300\text{K}$ $B_{20k} := 19980\text{Hz}$ $B_1 := 1\text{Hz}$
 $f := 10\text{Hz}, 20\text{Hz}.. 100 \cdot 10^3\text{Hz}$ $v_{i,nom} := 0.5 \cdot 10^{-3}\text{V}$ $h := 10^3\text{Hz}$

1. Mr Popa's statements:

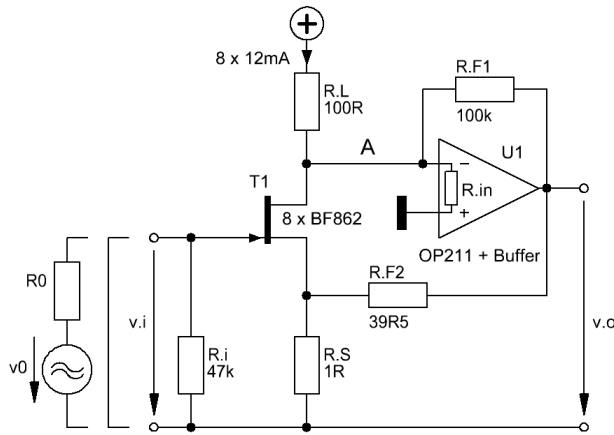

$e_{n.i.calk} := 0.33 \cdot 10^{-9}\text{V}$
 $e_{n.i.m} := 0.32 \cdot 10^{-9}\text{V}$
 $R_S := 1\Omega$
 $g_{m.gs} := 260 \cdot 10^{-3}\text{S}$

Fig. 1 HPS 5.1 principal circuitry with all noise relevant components

8xBF862 and Eq. (11): \Rightarrow $e_{n.i.p.gs} := \sqrt{\frac{6 \cdot k \cdot T \cdot B_1}{g_{m.gs}}}$ $e_{n.i.p.gs} = 309.166 \times 10^{-12}\text{V}$ (1)

$$20 \cdot \log\left(\frac{e_{n.i.calk}}{e_{n.i.p.gs}}\right) = 0.566 \text{ [dB]}$$

BF862: $I_{D,1} := 12 \cdot 10^{-3}\text{A}$ $I_{D,8} := I_{D,1} \cdot 8$

2. BUVO calculations:

Basic equation to calculate the head-amp's open-loop output noise voltage density $e_{n.o,0}(f,R_0)$, as function of frequency f (reflecting JFET 1/f-noise and R_S, R_L excess noise impacts) and a potential input load R_0 .

The sequence of a transconductance amp (cascode amp with JFET followed by a BJT = T1) and a transimpedance amp (= U1) yields the overall open-loop gain $G_{tot,0} = g_{m1} \cdot R_{F1}$:

$$e_{n.o,0}(f,R_0) = \sqrt{\left[e_{n.i.8JFET}(f)^2 + e_{n.RS,eff}(f)^2 + e_{n.R0}(R_0)^2 + \left(\frac{e_{n.i.op211}}{G_{1st}}\right)^2 \right] \cdot (g_{m.8,red} \cdot R_{F1})^2 \dots + i_{n.RL,eff}(f)^2 \cdot R_{F1}^2 + i_{n.i.op211}^2 \cdot R_{F1}^2 + e_{n.RF1}^2}$$



2.1 Additional basic circuitry values (V_E = Early voltage of the BF862):

$R_0 := 0.001 \Omega, 1 \Omega .. 100 \Omega$	$R_L := 100 \Omega$	$R_i := 47.5 \cdot 10^3 \Omega$	$R_{F1} := 100 \cdot 10^3 \Omega$
$g_{m.1} := 40 \cdot 10^{-3} S$	$g_{m.8} := 8 \cdot g_{m.1}$	$g_{m.8} = 320 \times 10^{-3} S$	$R_{F2} := 39.5 \cdot \Omega$
$i_{n.i.op211} := 1.7 \cdot 10^{-12} A$	$e_{n.i.op211} := 1.1 \cdot 10^{-9} V$	$f_{c.e} < 20 Hz$ $f_{c.i} \leq 20 Hz$	$G_{o.e} := 130 \text{ [dB]}$
$R_{in.op211} := 20 \cdot 10^3 \Omega$	$V_E := -80V$	$G_o := 10^{\frac{G_{o.e}}{20}}$	$G_o = 3.162 \times 10^6$

Assumptions: R_S is 1% - 0.6W - 1R metal thin film resistors, R_L is 1% 3W metall thin film resistor (5 paralleled 1% - 0.6W - 499R), all having a noise current index NI_e of -24dB

$NI_{e.RL} := -24 \text{ [dB]}$	$NI_{RL} := 10^{\frac{NI_{e.RL}}{20}} \cdot 10^{-6}$	$NI_{RL} = 63.096 \times 10^{-9}$	$d := 3$
$NI_{e.RS} := -24 \text{ [dB]}$	$NI_{RS} := 10^{\frac{NI_{e.RS}}{20}} \cdot 10^{-6}$	$NI_{RS} = 63.096 \times 10^{-9}$	

2.2 Basic noise current relevant calculations :

2.2.1 Gain of the JFET/BJT (= T1) cascode stage :

$g_{m.8.red} := \frac{g_{m.8}}{1 + g_{m.8} \cdot R_S}$	$g_{m.8.red} = 242.424 \times 10^{-3} S$	$G_{1st} := g_{m.8.red} \cdot R_L$	$G_{1st} = 24.242$
--	--	------------------------------------	--------------------

2.2.2 Noise current of the JFET x 8:

$i_{n.8JFET} := \sqrt{\frac{8}{3} \cdot k \cdot T \cdot 8 \cdot g_{m.1} \cdot B_1}$	$i_{n.8JFET} = 59.451 \times 10^{-12} A$
---	--

2.2.3 Other important noise current sources:

$i_{n.RL} := \sqrt{4 \cdot k \cdot T \cdot \frac{B_1}{R_L}}$	$i_{n.RL} = 12.872 \times 10^{-12} A$
--	---------------------------------------

$e_{Nex.RL}(f) := \sqrt{\left(\frac{\frac{NI_{e.RL}}{10} \cdot 10^{-12}}{\ln(10)} \right) \cdot \frac{(I_{D.8} \cdot R_L)^2 \cdot B_1}{f}}$	$e_{Nex.RL}(h) = 12.623 \times 10^{-9} V$
--	---

$e_{nex.RL}(f) := e_{Nex.RL}(f) \cdot \sqrt{\frac{B_1}{B_{20k}}}$	$e_{nex.RL}(h) = 89.303 \times 10^{-12} V$
---	--



$$i_{n,RL}^{(f)} := \frac{e_{n,ex,RL}^{(f)}}{R_L} \qquad i_{n,ex,RL}^{(h)} = 893.029 \times 10^{-15} \text{ A}$$

$$i_{n,RL,eff}^{(f)} := \sqrt{i_{n,RL}^2 + i_{n,ex,RL}^{(f)2}} \qquad i_{n,RL,eff}^{(h)} = 12.903 \times 10^{-12} \text{ A}$$

2.2.4 Drain-source resistance r_{DS} of the JFET x 8:

$$r_{DS,1} := \frac{|V_E|}{I_{D,1}} \qquad r_{DS,1} = 6666.667 \ \Omega \qquad r_{DS,8} := \frac{r_{DS,1}}{8} \qquad r_{DS,8} = 833.333 \ \Omega$$

2.2.5. Total noise current $i_{n,A}$ at the input of U1 at point A:

$$i_{n,A}^{(f)} := \sqrt{i_{n,iop211}^2 + i_{n,RL,eff}^{(f)2} + i_{n,8JFET}^2 + \left[\frac{e_{n,iop211}}{(R_L^{-1} + r_{DS,8}^{-1})^{-1}} \right]^2} \qquad i_{n,A}^{(h)} = 62.094 \times 10^{-12} \text{ A}$$

2.3 Basic noise voltage relevant calculations :

2.3.1 Noise voltage of the JFET x 8:

$$f_c \text{ picked from Fig.1: } \qquad f_c := 1.1 \cdot 10^3 \text{ Hz}$$

$$e_{n,i,8JFET} := \sqrt{\frac{8 \cdot k \cdot T \cdot B_1}{3 \cdot 8 \cdot g_{m,1}}} \qquad e_{n,i,8JFET} = 185.785 \times 10^{-12} \text{ V}$$

$$e_{n,i,8JFET}^{(f)} := e_{n,i,8JFET} \sqrt{\frac{f_c}{f} + 1} \qquad e_{n,i,8JFET}^{(h)} = 269.229 \times 10^{-12} \text{ V}$$

$$e_{n,o,8JFET}^{(f)} := G_{1st} \cdot e_{n,i,8JFET}^{(f)} \qquad e_{n,o,8JFET}^{(h)} = 6.527 \times 10^{-9} \text{ V}$$

2.3.1 Other important noise voltage sources (R_0, R_{F1}, R_{FB}, R_S):

$$R_{0,eff}(R_0) := (R_0^{-1} + R_i^{-1})^{-1} \qquad R_0 = 10^6 \ \Omega = \text{input shorted:} \qquad R_{0,eff}(10^{-6} \ \Omega) = 1000 \times 10^{-9} \ \Omega$$

$$e_{n,R_0,eff}(R_0) := \sqrt{4 \cdot k \cdot T \cdot R_{0,eff}(R_0) \cdot B_1} \qquad e_{n,R_0,eff}(10^{-6} \ \Omega) = 128.716 \times 10^{-15} \text{ V}$$

$$e_{n,R_{F1}} := \sqrt{4 \cdot k \cdot T \cdot R_{F1} \cdot B_1} \qquad e_{n,R_{F1}} = 40.704 \times 10^{-9} \text{ V}$$

$$R_{FB} := (R_S^{-1} + R_{F2}^{-1})^{-1} \qquad R_{FB} = 975.309 \times 10^{-3} \ \Omega$$

$$e_{n,R_{FB}} := \sqrt{4 \cdot k \cdot T \cdot R_{FB} \cdot B_1} \qquad e_{n,R_{FB}} = 127.117 \times 10^{-12} \text{ V}$$

$$e_{Nex,RS}^{(f)} := \sqrt{\left(\frac{NI_{e,RS}}{10^{10} \cdot 10^{-12}} \right) \cdot \frac{(I_{D,8} R_S)^2 \cdot B_1}{f}} \qquad e_{Nex,RS}^{(h)} = 126.23 \times 10^{-12} \text{ V}$$



$$e_{n.RS.tot}(f) := \sqrt{e_{n.FB}^2 + e_{Nex.RS}(f)^2 \cdot \frac{B_1}{B_{20k}}} \quad e_{n.RS.tot}(h) = 127.12 \times 10^{-12} \text{V}$$

$$e_{n.RS.eff}(f) := \sqrt{e_{n.RS.tot}(f)^2 + i_{n.8JFET}^2 \cdot R_{FB}^2} \quad e_{n.RS.eff}(h) = 139.72 \times 10^{-12} \text{V}$$

2.3.2 Calculated noise voltage density $e_{n.o.0}$ at the output of U1 and the input referred noise voltage density $e_{n.i.amp}$ of the whole head-amp, input shorted:

$$G_{tot.0} := g_{m.8.red} R_{F1} \quad G_{tot.0} = 24.242 \times 10^3 \quad R_0 := 10^{-6} \Omega$$

$$e_{n.o.0}(f, R_0) := \sqrt{\left[e_{n.i.8JFET}(f)^2 + e_{n.RS.eff}(f)^2 + e_{n.R0.eff}(R_0)^2 + \left(\frac{e_{n.i.op211}}{G_{1st}} \right)^2 \right] \cdot (g_{m.8.red} R_{F1})^2 \dots} \\ + i_{n.RL.eff}(f)^2 \cdot R_{F1}^2 + i_{n.i.op211}^2 \cdot R_{F1}^2 + e_{n.RF1}^2$$

$$e_{n.o.0}(h, R_0) = 7.548 \times 10^{-6} \text{V}$$

$$e_{n.i.amp}(f, R_0) := \frac{e_{n.o.0}(f, R_0)}{G_{tot.0}} \quad e_{n.i.amp}(h, R_0) = 311.367 \times 10^{-12} \text{V}$$

2.4 Development of additional Fig.2 trace equations:

2.4.1 JFET traces equations:

$$e_{n.i.1}(f) := e_{n.i.8JFET}(10^9 \text{Hz}) \quad e_{n.i.2}(f) := e_{n.i.8JFET}(10^9 \text{Hz}) \cdot \sqrt{\frac{f_c}{f}}$$

2.4.2 Head-amp trace equation:

$$e_{n.i.amp.1}(f, R_0) := e_{n.i.amp}(10^9 \text{Hz}, R_0) \quad e_{n.i.amp.1}(10^9 \text{Hz}, R_0) = 242.831 \times 10^{-12} \text{V}$$

2.4.3 Simulation of the upper trace of Mr Popa's web-site graph:

Determination of R_X (= difference in Ohm between calculated input referred noise voltage density $e_{n.i.amp}$ and the simulation of Mr Popa's upper graph HPS 5.1, hanged up at the measurement result $e_{n.i.popa}$ at 1,059Hz) :

$$e_{n.i.popa} := 314.187 \cdot 10^{-12} \text{V} \quad R_X := \frac{e_{n.i.popa}^2 - e_{n.i.amp}(1059 \text{Hz}, R_0)^2}{4 \cdot k \cdot T \cdot B_1}$$

$$R_X = 0.234 \Omega \quad e_{n.RX} := \sqrt{4 \cdot k \cdot T \cdot R_X \cdot B_1} \quad e_{n.RX} = 62.292 \times 10^{-12} \text{V} \quad e_{n.RX}(f) := e_{n.RX}$$

$$e_{n.i.popa}(f, R_0) := \sqrt{e_{n.i.amp}(f, R_0)^2 + e_{n.RX}(f)^2} \quad e_{n.i.popa2}(f, R_0) := \sqrt{(e_{n.i.amp}(10^9 \text{Hz}, R_0))^2 + e_{n.RX}(10^9 \text{Hz})^2}$$



2.4.4 Fig. 3 of the letter to LIA

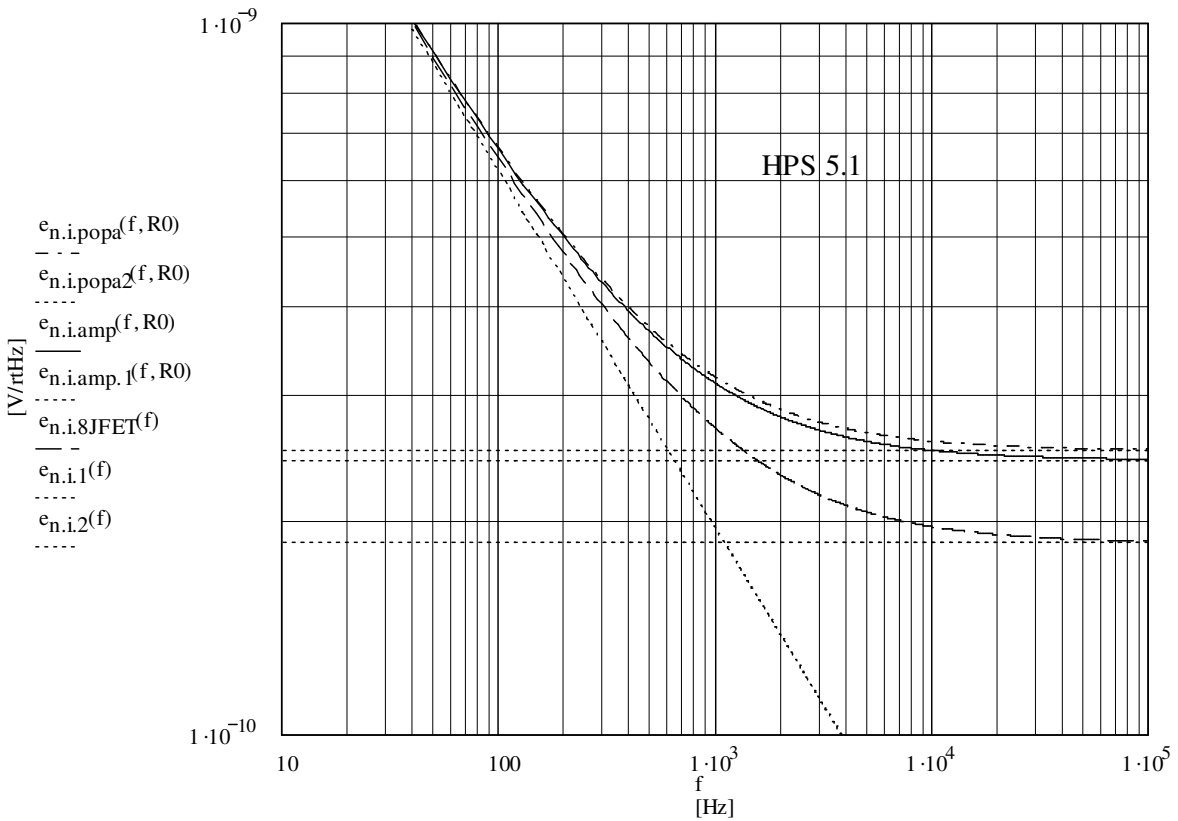

Fig. 2 = Fig. 3 of the BuVo letter

2.4.4 Comparison with Mr Popa's 1,059Hz values:

$$e_{n.i.amp}(1059\text{Hz}, R0) = 307.95 \times 10^{-12} \text{V}$$

$$e_{n.i.popa1} := 314.187 \times 10^{-12} \text{V} = \{1\}$$

$$e_{n.i.popa2} := 326.157 \cdot 10^{-12} \text{V} = \{2\}$$

$$20 \cdot \log \left(\frac{e_{n.i.amp}(1059\text{Hz}, R0)}{e_{n.i.popa1}} \right) = -0.174 \quad [\text{dB}]$$

$$20 \cdot \log \left(\frac{e_{n.i.amp}(1059\text{Hz}, R0)}{e_{n.i.popa2}} \right) = -0.499 \quad [\text{dB}]$$



3. SN calculations of the non-equalized head-amp with input shorted:

3.1 SN calculations

$$SN_{i,amp} := 20 \cdot \log \left[\frac{\sqrt{\frac{1}{B_{20k}} \cdot \int_{20\text{Hz}}^{20000\text{Hz}} \left(|e_{n,i,amp}(f, R0) | \right)^2 \cdot \frac{B_{20k}}{B_1} df}}{v_{i,nom}} \right] \quad SN_{i,amp} = -82.399 \quad [\text{dB}]$$

$$SN_{i,popa} := 20 \cdot \log \left[\frac{\sqrt{\frac{1}{B_{20k}} \cdot \int_{20\text{Hz}}^{20000\text{Hz}} \left(|e_{n,i,popa}(f, R0) | \right)^2 \cdot \frac{B_{20k}}{B_1} df}}{v_{i,nom}} \right] \quad SN_{i,popa} = -82.171 \quad [\text{dB}]$$

$$SN_{i,D} := SN_{i,amp} - SN_{i,popa} \quad SN_{i,D} = -0.228 \quad [\text{dB}]$$

3.2 Evaluation of the head-amp's calculated average input referred noise voltage density $e_{n,i,avg1}$ in B_{20k} :

$$e_{n,i,avg1} := 10^{\frac{SN_{i,amp}}{20}} \cdot \sqrt{\frac{B_1}{B_{20k}}} \cdot v_{i,nom} \quad e_{n,i,avg1} = 268.372 \times 10^{-12} \text{V} \quad (2)$$

$$20 \cdot \log \left(\frac{e_{n,i,avg1}}{e_{n,i,calc}} \right) = -1.796 \quad [\text{dB}]$$

3.3 Evaluation of the average input referred noise voltage density $e_{n,i,avg2}$ in B_{20k} of the simulated noise spectrum of Mr Popa's head-amp

$$e_{n,i,avg2} := 10^{\frac{SN_{i,popa}}{20}} \cdot \sqrt{\frac{B_1}{B_{20k}}} \cdot v_{i,nom} \quad e_{n,i,avg2} = 275.506 \times 10^{-12} \text{V} \quad (3)$$

4. SN calculations of the non-equalized head-amp and the RIAA equalized phono-amp, both with input loaded:

$$R0 := 20\Omega \quad e_{n,R0,eff}(R0) = 575.514 \times 10^{-12} \text{V}$$

$$T1 := 318 \cdot 10^{-6} \text{s} \quad T2 := 3180 \cdot 10^{-6} \text{s} \quad T3 := 75 \cdot 10^{-6} \text{s}$$



A-weighting transfer F(f):
$$F(f) := \frac{1.259}{\left[1 + \left(\frac{20.6\text{Hz}}{f}\right)^2\right] \cdot \sqrt{1 + \left(\frac{107.7\text{Hz}}{f}\right)^2} \cdot \sqrt{1 + \left(\frac{737.9\text{Hz}}{f}\right)^2} \cdot \left[1 + \left(\frac{f}{12200\text{Hz}}\right)^2\right]}$$

RIAA transfer R(f):
$$R(f) := \left[\frac{\sqrt{1 + (2 \cdot \pi \cdot f \cdot T1)^2}}{\sqrt{1 + (2 \cdot \pi \cdot f \cdot T2)^2} \cdot \sqrt{1 + (2 \cdot \pi \cdot f \cdot T3)^2}} \right] \cdot \left[\frac{\sqrt{1 + (2 \cdot \pi \cdot h \cdot T1)^2}}{\sqrt{1 + (2 \cdot \pi \cdot h \cdot T2)^2} \cdot \sqrt{1 + (2 \cdot \pi \cdot h \cdot T3)^2}} \right]^{-1}$$

4.1 Detailed SN calculations incl. 1/f-noise impact :

$$SN_{ne.20R} := 20 \cdot \log \left[\frac{\sqrt{\frac{1}{B_{20k}} \cdot \int_{20\text{Hz}}^{20000\text{Hz}} \left[\left(|e_{n.i.amp}(f, R0) \right)^2 \right] \cdot \frac{B_{20k}}{B_1} df}}{v_{i.nom}} \right] \quad SN_{ne.20R} = -74.918 \quad [\text{dB}]$$

$$SN_{ne.a.20R} := 20 \cdot \log \left[\frac{\sqrt{\frac{1}{B_{20k}} \cdot \int_{20\text{Hz}}^{20000\text{Hz}} \left[\left(|e_{n.i.amp}(f, R0) \right)^2 \right] \cdot \frac{B_{20k}}{B_1} \cdot F(f)^2 df}}{v_{i.nom}} \right] \quad SN_{ne.a.20R} = -76.987 \quad [\text{dB(A)}]$$

$$SN_{riaa.20R} := 20 \cdot \log \left[\frac{\sqrt{\frac{1}{B_{20k}} \cdot \int_{20\text{Hz}}^{20000\text{Hz}} \left(|e_{n.i.amp}(f, R0) \right)^2 \cdot \frac{B_{20k}}{B_1} \cdot R(f)^2 df}}{v_{i.nom}} \right] \quad SN_{riaa.20R} = -75.485 \quad [\text{dB}]$$

$$SN_{ariaa.20R} := 20 \cdot \log \left[\frac{\sqrt{\frac{1}{B_{20k}} \cdot \int_{20\text{Hz}}^{20000\text{Hz}} \left[\left(|e_{n.i.amp}(f, R0) \right)^2 \right] \cdot \frac{B_{20k}}{B_1} \cdot R(f)^2 \cdot F(f)^2 df}}{v_{i.nom}} \right] \quad SN_{ariaa.20R} = -82.645 \quad [\text{dB(A)}]$$

4.2 Rough cross-check without 1/f-noise impact and without the noise of the JFET's drain circuitry (with $f_c = 10^{-6}\text{Hz}$ the above given SNs should become very close to the below calculated SN values):

$$e_{n.i.tot} := \sqrt{\frac{8}{3} \cdot \frac{k \cdot T \cdot B_1}{g_{m.1} \cdot 8} + 4 \cdot k \cdot T \cdot R_S \cdot B_1 + R_S^2 \cdot \frac{8}{3} \cdot k \cdot T \cdot 8 \cdot g_{m.1} \cdot B_1 + 4 \cdot k \cdot T \cdot R_{0eff}(R0) \cdot B_1}$$

$SN_r := -3.646 \quad [\text{dB}] \quad SN_{ar} := -7.935 \quad [\text{dB}] \quad SN_a := -2.046 \quad [\text{dB}]$



$$SN_{ne.R0} := 20 \cdot \log \left(\frac{e_{n.i.tot} \sqrt{\frac{B_{20k}}{B_1}}}{0.5 \cdot 10^{-3} V} \right) \quad SN_{ne.R0} = -75.109 \quad [dB]$$

$$SN_{ne.a.R0} := SN_{ne.R0} + SN_a \quad SN_{ne.a.R0} = -77.155 \quad [dB(A)]$$

$$SN_{riaa.R0} := SN_{ne.R0} + SN_r \quad SN_{riaa.R0} = -78.755 \quad [dB]$$

$$SN_{ariaa.R0} := SN_{ne.R0} + SN_{ar} \quad SN_{ariaa.R0} = -83.044 \quad [dB(A)]$$

4.3 Rough alternative gain-stage (gs) average B_{20k} input noise voltage $e_{n.i.avg3}$ calculation via the equivalent JFET noise resistance incl. 1/f-noise, input shorted

$$F_c := \frac{f_c \cdot \ln \left(\frac{20000 \text{ Hz}}{20 \text{ Hz}} \right) + B_{20k}}{B_{20k}} \quad F_c = 1.38$$

$$r_{N.8} := \frac{2}{3 \cdot 8 \cdot g_{m.1}} \quad r_{N.8} = 2.083 \Omega$$

$$e_{n.rN.8} := \sqrt{4 \cdot k \cdot T \cdot r_{N.8} \cdot B_1 \cdot F_c} \quad e_{n.rN.8} = 218.273 \times 10^{-12} V$$

$$e_{n.RS} := \sqrt{4 \cdot k \cdot T \cdot R_S \cdot B_1} \quad e_{n.RS} = 128.716 \times 10^{-12} V$$

$$e_{n.i.gs.avg3} := \sqrt{\frac{8}{3} \cdot \frac{k \cdot T \cdot B_1}{g_{m.1} \cdot 8} \cdot F_c + 4 \cdot k \cdot T \cdot R_S \cdot B_1} \quad e_{n.i.gs.avg3} = 253.399 \times 10^{-12} V \quad (4)$$

4.4 Rough data sheet (ds) based input noise voltage density $e_{n.i.avg4}$ approximation, incl. 1/f-noise, input shorted

from ds: $e_{n.ids} := 0.8 \cdot 10^{-9} V$ at 100kHz and at $g_m = ?$

to get g_m succ-apps of $g_{m.ds}$ should match (a) and (b) $g_{m.ds} := 17.2581 \cdot 10^{-3} S$

8 JFETs paralleled: $\frac{0.8 \cdot 10^{-9} V}{\sqrt{8}} = 282.843 \times 10^{-12} V$ (a)

$$e_{n.ids.8} := \sqrt{\frac{8}{3} \cdot \frac{k \cdot T \cdot B_1}{g_{m.ds} \cdot 8}} \quad e_{n.ids.8} = 282.843 \times 10^{-12} V \quad (b)$$

$$e_{n.i.gs.avg4} := \sqrt{e_{n.ids.8}^2 \cdot F_c + 4 \cdot k \cdot T \cdot R_S \cdot B_1} \quad e_{n.i.gs.avg4} = 356.36 \times 10^{-12} V \quad (5)$$



4.5 Rough input noise voltage density $e_{n,i,avg5}$ approximation of the 8 x JFET and R_S ,
excl. 1/f-noise, input shorted

$$e_{n,i,gs,avg4} := \sqrt{e_{n,i,ds,8}^2 + 4 \cdot k \cdot T \cdot R_S \cdot B_1} \qquad e_{n,i,gs,avg4} = 310.754 \times 10^{-12} \text{V} \quad (6)$$

5. Calculation of the output noise current of a simple active constant current source

The basic equation to calculate the output noise current $i_{n,o1}$ of a BJT driven constant current source CCS becomes:

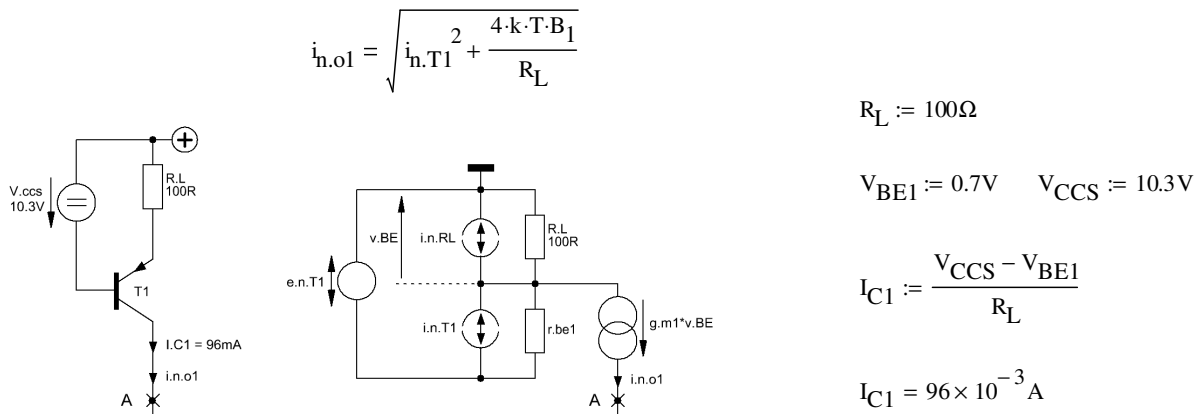

Fig. 3 CCS circuit (left) and noise relevant equivalent circuit (right)

$$g_{m1} := \frac{I_{C1}}{k \cdot T} \cdot q \qquad g_{m1} = 3.713 \text{ S} \qquad h_{FE1} := 400 \qquad r_{be1} := \frac{h_{FE1}}{g_{m1}} \qquad r_{be1} = 107.715 \Omega \qquad r_{bb1} := 10 \Omega$$

$$i_{n,T1} := \sqrt{\frac{2 \cdot q \cdot I_{C1}}{h_{FE1}} \cdot B_1} \qquad i_{n,T1} = 8.77 \times 10^{-12} \text{ A} \qquad i_{n,RL} := \sqrt{\frac{4 \cdot k \cdot T \cdot B_1}{R_L}} \qquad i_{n,RL} = 12.872 \times 10^{-12} \text{ A}$$

$$e_{n,T1} := \sqrt{B_1 \cdot \left(\frac{2 \cdot k^2 \cdot T^2}{q \cdot I_{C1}} + \frac{2 \cdot q \cdot I_{C1} \cdot r_{bb1}^2}{h_{FE1}} + 4 \cdot k \cdot T \cdot r_{bb1} \right)} \qquad e_{n,T1} = 419.046 \times 10^{-12} \text{ V}$$

$$i_{n,o1} := \sqrt{i_{n,T1}^2 + \frac{4 \cdot k \cdot T \cdot B_1}{R_L}} \qquad i_{n,o1} = 15.575 \times 10^{-12} \text{ A} \qquad \frac{i_{n,o1}}{i_{n,RL}} = 1.21 \quad (7)$$

$$e_{n,RL} := \sqrt{4 \cdot k \cdot T \cdot B_1 \cdot R_L}$$

$$e_{n,CCS} := \sqrt{e_{n,T1}^2 + e_{n,RL}^2} \qquad e_{n,CCS} = 1.354 \times 10^{-9} \text{ V} \qquad \frac{e_{n,CCS}}{e_{n,RL}} = 1.052$$

worst-case $V_E = 30 \text{V}$,
hence $G_{1st,adj}$ becomes:

$$V_E := -30 \text{V} \qquad r_{CE} := \frac{|V_E|}{I_{C1}} \qquad r_{CE} = 312.5 \Omega$$

$$G_{1st,adj} := (r_{CE} + R_L) \cdot g_{m,8,red} \qquad G_{1st,adj} = 100$$



Mr. Popa replies:

I am truly humbled that Mr. Burkhard Vogel took the time to sift through my L|A article, and through the information presented on my web site. Burkhard is one of the leaders in noise theory and analysis and his input is, as expected, consistent and complete.

It will take some time to absorb his detailed calculations (which are, at the first glance, entirely correct and also go well beyond the detail level (in particular adding the frequency dependencies) I was intending (given the L|A magazine profile) to put together in my article. As far as I can tell so far, Vogel's very interesting analysis and results do not seem to contradict the simplified analysis I have put together, for the use of the audio enthusiast community, and the experimental results with the HPS 5.1 head amp, by any significant margin.

Here are a few comments on the long debated CCS as a low noise gain stage load. Actually, a throughout analytic CCS noise analysis was done (considering even more contributions beyond the Early voltage/output impedance impact) in a 1975 IEEE paper [1].

- a) It is entirely correct that a CCS will increase the loop gain of the head amp. Loop gain is a resource much sought after, however one should never forget that it may come at a hefty price when it comes to closed loop stability; it is actually my intention to write an L|A follow-up precisely on the AC (and in particular on the loop gain) analysis of the HPS 5.1 head amp. What I can tell so far is that for modern wideband opamps with over 100dB open loop gain any further increase in the loop gain is barely going to bring any significant improvements here. As an example, a quick look at the new silicon-germanium OPA211 device will reveal a combination of DC, AC and noise performance that was very hard or even impossible to achieve in any discrete or prior integrated implementations.
- b) It is also entirely correct that a CCS load will decrease the opamp (or any second stage) voltage noise contribution to the total noise budget.
- c) Perhaps the nicest feature of a CCS load (which, for whatever reason, seem to be overlooked by most readers) is a dramatic improvement in the head amp PSRR. In achieving a $\sim 0.3\text{nV}/\text{rtHz}$ noise performance, the low noise stage PSRR is probably the most difficult issue to deal with. Again, a future article will show how to deal with this in an elegant way, using the opamp common mode rejection properties.
- d) I still maintain (and Mr. Vogel's detailed calculations do not seem to debate this point) that a head amp based on the HPS 5.1 architecture and augmented with a CCS load in the first (JFET) low noise stage will have, under most circumstances, a worse noise performance compared to a pure resistive load. I have already mentioned the challenge for somebody to show a modified HPS 5.1 design, using a CCS load, with improved noise performance compared to the current HPS 5.1 design. The challenge is still up and if somebody has a sound solution then I am willing to implement, measure the performance, and publish it with all the credits granted.
- e) But my biggest problem with the CCS load approach is that it is impossible to simply replace the resistive load in the current HPS 5.1 design; DC bias constraints are imposing the use of a second servo to define and stabilize the JFET drain voltage. This would not only significantly increase the design complexity, but also affect the noise budget, making the noise performance of such a new design as whole less predictable and, most likely, worse.

[1] Bilotti, A.; Mariani, E.; "Noise characteristics of current mirror sinks/sources," Solid-State Circuits, IEEE Journal of , vol.10, no.6, pp. 516- 524, Dec 1975